



BHAGYANAGAR GAS LIMITED
(A JOINT VENTURE OF HPCL & GAIL)

BID DOCUMENT FOR

**Procurement of Decompression Units (DCU) parts
and to assemble for Installation in various societies
for Supply of Natural Gas to D-PNG consumers in
Hyderabad**

**UNDER OPEN DOMESTIC
COMPETITIVE BIDDING**

Bid Document No.: BGL/556/2022-23

VOLUME-II of II



Bhagyanagar Gas Limited

**Procurement of Decompression Units (DCU) parts and
to assemble for Installation in various societies for
Supply of Natural Gas to D-PNG consumers in
Hyderabad
Bid Document No. BGL/556/2022-23**

**Volume
II of II**

CONTENTS

Volume II of II

Sl. No.	DESCRIPTION
SECTION-7	SPECIAL CONDITIONS OF CONTRACT (SCC)
SECTION-8	MATERIAL REQUISITION, SCOPE OF SUPPLY & TECHNICAL SPECIFICATION
SECTION-10	SCHEDULE OF RATES/ PRICE SCHEDULE



Bhagyanagar Gas Limited

**Procurement of Decompression Units (DCU) parts and
to assemble for Installation in various societies for
Supply of Natural Gas to D-PNG consumers in
Hyderabad
Bid Document No. BGL/556/2022-23**

**Volume
II of II**

SPECIAL CONDITIONS OF CONTRACT (SCC)

GENERAL

- 1.1 Special Conditions of Contract shall be read in Conjunction with the General Conditions of Contract, Specification of work, Drawing and any other documents forming part of this Contract wherever the context so requires.
- 1.2 Notwithstanding the sub-division of the documents into these separate sections and volumes ever part of each shall be deemed to be supplementary to and complementary of every other part and shall be read with in the Contract so far as it may be practicable to do so.
- 1.3 Where any portion of the General Conditions of Contract is repugnant to or at variance with any provisions of the Special Conditions of Contract, unless a different intention appears, the provisions of the Special Conditions of Contract shall be deemed to over-ride the provisions of the General Conditions of Contract and shall be the extent of such repugnancy, or variations, prevail.
- 1.4 Wherever it is mentioned in the specification that the Contractor shall perform certain work or provide certain facilities, it is understood that the Contractor shall do so at his cost and the **Value of Contract** shall be deemed to have included cost of such performance and provisions, so mentioned.
- 1.5 The materials, design, and workmanship shall satisfy the relevant Indian Standard, the Job Specifications contained herein and Codes referred to where the job specification stipulate requirements in addition to those contained in the standard codes and specifications, these additional requirements shall also be satisfied.
- 1.6 In case of an irreconcilable conflict between Indian or other applicable standards, General Conditions of Contract, Special Conditions of Contract, Specification, Drawings or Schedule of Rates, the following shall prevail to the extent of such irreconcilable conflict in order of precedence:
 - i) Letter of Acceptance/ FOI along with Statement of Agreed Variations.
 - ii) Schedule of Rates as enclosures to Letter of Acceptance
 - iii) Special Conditions of Contract
 - iv) Drawings
 - v) Technical/ Material Specifications
 - vi) Instruction to Bidder
 - vii) General Conditions of Contract
 - viii) Indian Standards
 - ix) Other applicable standards
- 1.7 It will be the Contractor's responsibility to bring to the notice of Engineer-in-charge any irreconcilable conflict in the contract documents before starting the work(s) or making the supply with reference which the conflict exists.
- 1.8 In the absence of any Specifications covering any material, design of work(s) the same shall be performed/ supplies/ executed in accordance with Standard Engineering Practice as per the instructions/ directions of the Engineer-in-charge, which will be binding on the Contractor.
- 1.9 The Bidder shall supply regulators, filters, CRV, SSV only from the approved list of manufacturers/make.



Bhagyanagar Gas Limited

**Procurement of Decompression Units (DCU) parts and
to assemble for Installation in various societies for
Supply of Natural Gas to D-PNG consumers in
Hyderabad
Bid Document No. BGL/556/2022-23**

**Volume
II of II**

2.0 SCOPE OF SUPPLY

The Scope of SUPPLY shall be as set out at Material Requisition, Data Sheets and Technical Specifications given in Volume-II of tender document and supplemented by all stipulation in the total tender document.

Seller's scope shall include

- (a) manufacturing of mentioned items as per Material Requisition technical specifications;
- (b) preparation of Quality Assurance / Quality control programme;
- (c) obtaining Owner's approval;
- (d) arranging Inspection and Testing certification;
- (e) Inspection and obtaining Inspection Release Note;
- (f) obtaining dispatch clearance;
- (g) Packing;
- (h) Transit Insurance, loading on truck/trailer including and Unloading of Gas Regulators/ spare kits at Bhagyanagar Gas's store/site.

3.0 CONTRACT PRICE

The contract price shall be deemed to be firm and valid for the entire duration of the contract till the completion of work, and shall not be subject to any adjustment due to increase in price of materials, utilities, or any. other input for performance of work and the contract except for increase/decrease in taxes and duties on account of subsequent legislation.

4.0 DIVISION OF ORDER

BGL reserves the right to divide the quantity among more than one bidder at its sole discretion and as mentioned in BEC of Vol I of II.

5.0 QUALITY ASSURANCE/QUALITY CONTROL:

- 5.1. The Contractor shall "prepare a detailed quality assurance plan for the execution of Contract for various facilities, which will be mutually discussed and agreed to.
- 5.2. The Contractor shall establish document and maintain an effective quality assurance system outlined in recognized codes.
- 5.3. The Purchaser while agreeing to a quality assurance plan shall mark the stages where they would like to witness the tests; review any or all stages of work at shop/site as deemed necessary for quality assurance.

6.0 QUANTITY VARIATION

The tendered quantity may vary depending upon the project requirement. BGL reserves the right to decrease/ increase the quantity depending upon its requirement.

7.0 DISPATCH INSTRUCTIONS

- 7.1 Seller shall obtain dispatch clearance from the Purchaser prior to each dispatch.
- 7.2. Copy of Inspection Release Certificate, Dispatch Clearance and statement showing the name of the Vessel/Trailers description and weight of material and shipping marks etc. to be submitted along with the documents.



8.0 INSPECTION

Final inspection of the pipe shall only be done by TPIA approved by BGL. All the charges towards all kinds of tests/TPIA cost shall be included in the quoted rates per unit. No additional payment to this effect will be made. The charges towards BGL's Inspection Agency, if engaged, shall be borne by Vendor.

9.0 REJECTION

- 9.1. Any materials/goods covered under scope of supply, which during the process of inspection by appointed third party, at any stage of manufacture/fabrication, and subsequent stages, prior to dispatch is found not conforming to the requirements/specifications of the Purchase Requisition /Order, shall be liable for immediate rejection.
- 9.2. Supplier shall be responsible and liable for immediate replacement of such material with acceptable material at no extra cost or impact on the delivery schedule to EMPLOYER

10.0 TERMS OF PAYMENTS

The Payment shall be made in the following manner subject to completion of all contractual requirements as per tender document.

The following shall be read in conjunction with Clauses of GCC (Goods)

- **100 % (Hundred percent) payment of the supplied portion along with freight including taxes & duties will be paid on receipt & acceptance of goods at FOT site after adjustment of PRS, if any along with submission of following documents: -**
 - i) Original Invoice in triplicate in compliance with GST law in force
 - ii) Inspection Release note by Owner or his appointed or approved agency.
 - iii) Original GR / LR
 - iv) Packing List
 - v) Insurance cover note covering transit insurance
 - vi) Performance Bank Guarantee(s) of 10% of Contract Value. If already submitted, a copy of the same.
 - vii) Document related to Input Tax Credit (ITC) to be claimed by owner, if applicable.
- **For FINAL BILL, following documents are to be provided:**
 - v) **No Claim & No due Certificate**
 - vi) Statement of Completion

ii. *MODE OF PAYMENT*

All payments payable in Indian rupees against the contract shall be released by Owner through account payee cheque payable at par or by electronic transfer.

iii. *DEDUCTION AT SOURCE*

Purchaser will release the payment to the Seller after effecting deductions as per applicable law in force. Purchaser will release payments by F&A Dept, BGL to the Contractor after offsetting all dues to the Purchaser payable by the Contractor under the Contract.

11.0 COMPENSATION FOR DELAY (PRICE REDUCTION / LIQUIDATED DAMAGES)

In case of delay in delivery of materials beyond contractually agreed delivery schedule, price reduction schedule will be applicable @0.5% of material value for the unsupplied portion per week of delay or part thereof, subject to ceiling of 5% (FIVE PERCENT) of the total order value. For details, please refer relevant clause of GCC-Goods.



Bhagyanagar Gas Limited

Procurement of Decompression Units (DCU) parts and to assemble for Installation in various societies for Supply of Natural Gas to D-PNG consumers in Hyderabad
Bid Document No. BGL/556/2022-23

Volume
II of II

The value referred in PRS clause is excluding taxes & duties.

12.0 PERFORMANCE BANK GUARANTEE SECURITY DEPOSIT:

Bidder will provide Performance Guarantee @ 3 % of annualized order value within 30 days of receipt of Fax of Acceptance (FOA) / Work Order (WO) from the Owner. The contract performance bank guarantee shall be valid 3 months beyond the Guarantee/Warranty period.

The Performance Guarantee shall be in form of either Demand Draft or Banker's Cheque or bank transfer through NEFT/RTGS/IMPS into BGL account, or irrevocable Bank Guarantee and shall be in the currency of Contract (issued by any Indian Scheduled bank or a branch of an International Bank situated in India and registered with Reserve Bank of India as Scheduled Foreign Bank). The Terms also to be read in line with Section Information to Bidders (ITB) (Vol I of II) of Bid Document.

There is no exemption to MSEs including SSI units from submission of Security Deposit/ Contract Performance Bank Guarantee (CPBG).

13.0 REPEAT ORDER

BGL reserves the right to place a repeat order within Six (06) months from date of purchase order for upto 50% of order quantities on same rate, terms and conditions.

14.0 DELIVERY

The delivery of the items location wise is as per the Material Requisition.

The Vendor to arrange transportation of these materials from the vendor shop to designated locations of BGL yard in respective cities. No extra payment shall be made for the transportation and deemed to be included in the quoted price.

Bidder to deliver the materials at all locations as per the quantity estimated.

15.0 DELIVERY SCHEDULE

Delivery of the total order quantity will be completed within 6-8 weeks for the supply of all materials as per SOR, from the date of receipt of LOI/PO from the date of Fax of Acceptance (FOA)/Purchase Order (PO).

16.0 PACKING, MARKING AND SHIPMENT

The Seller, wherever applicable shall after proper painting, pack and crate all goods for sea/air/road/rail transportation in a manner suitable to tropical humid climatic region in accordance with the internationally accepted practices and in such a manner so as to protect it from damage and deterioration, in transit by sea or air or road or rail and during storage at the storehouse. The Seller shall be held responsible for all damages due to improper packing. The Seller shall ensure sizing or packing of all oversized consignments in such a way that availability of carrier and/or road/rail route is properly taken into consideration.

For MARKING & PACKAGING of the Materials shall be as Section-IV of Vol I of I.

Seller shall comply with the Packing, Marking and Shipping Instructions and Special Packaging Requirement as per Vol I of II of this Bidding Document.



Bhagyanagar Gas Limited

**Procurement of Decompression Units (DCU) parts and
to assemble for Installation in various societies for
Supply of Natural Gas to D-PNG consumers in
Hyderabad
Bid Document No. BGL/556/2022-23**

**Volume
II of II**

17.0 INDEPENDENT SELLER

It is expressly understood and agreed that Seller is an independent party and that neither the Seller/ its personnel are servants, agents or employees of Purchaser nor the Seller has any kind of interest in other sellers.

18.0 LIEN

Seller shall ensure that the Scope of Supply supplied under the Agreement shall be free from any claims of title/liens from any third party. In the event of such claims by any party, Seller shall at his own cost defend, indemnify and hold harmless Purchaser or its authorized representative from such disputes of title/liens, costs, consequences etc.

19.0 LIMITATION OF LIABILITY

Notwithstanding anything contrary contained herein, the aggregate total liability of Supplier under the Contract or otherwise shall be limited to 100% of contract value. However, neither party shall be liable to the other party for any indirect and consequential damages, loss of profits or loss of production.

20.0 GOVERNING LAW

Laws of India will govern the Agreement and Hyderabad courts will have exclusive jurisdiction on all matters related to Agreement.

21.0 OWNER'S RIGHTS AND REMEDIES

Without prejudice to Owner's right and remedies under Agreement, if SUPPLIER fails to commence delivery as per agreed schedule and/or in reasonable opinion of the OWNER, CONTRACTOR is not in a position to make up the delay to meet the intended purpose, the OWNER may terminate the AGREEMENT in full or part at SUPPLIER's default and may get supplies from other sources at SUPPLIER's risk and cost.

22.0 TRANSIT INSURANCE (addtl to Clause no. 16.0 of GCC)

Bidder shall arrange Transit Insurance and the cost of which shall be borne by bidder. Quoted price shall be inclusive of the same.

23.0 WARRANTY

If any trouble or defect, originating with the design, material, workmanship or operating characteristics of any materials, arises at any time prior to expiry of twelve(12) months from the date of commissioning of the equipment or prior to expiry of twenty four (24) months from the date of last shipment (particular delivery LOT for Groups) whichever is earlier, first expire, and the SELLER is notified thereof, SELLER shall, at his own expense and as promptly as possible, make such alterations, repairs and replacements as may necessary to permit the materials to function in accordance with the specifications and to fulfill the foregoing guarantees.

24.0 General Conditions:

- (i) When the materials are dispatched to the consignee intimation must also be given to this effect. Reference to the supply order should invariably be given in all the relevant correspondence.
- (ii) The tender is liable to be rejected in case the tender does not comply with tender stipulations or the goods, works and services offered do not conform to the required specifications indicated their in.
- (iii) Any other terms and conditions offered by the firm and not included in the order/contract, are not acceptable to BGL.

Sign & Seal of Bidder



Bhagyanagar Gas Limited

**Procurement of Decompression Units (DCU) parts and
to assemble for Installation in various societies for
Supply of Natural Gas to D-PNG consumers in
Hyderabad**

Bid Document No. BGL/556/2022-23

**Volume
II of II**

25.0 Location/Site Information:

Location of site will be informed by BGL Engineer-In-charge OR as follows

For Hyderabad Location:

Bhagyanagar Gas Limited,
Sy No. 1266, Mother Station,
CNG Gas Station, Opp. Nalsar University
Adjacent to IPE Collage
Shamirpet, Hyderabad-500078
Rangareddy, Telangana



Bhayanagar Gas Limited

**Procurement of Decompression Units (DCU) parts and
to assemble for Installation in various societies for
Supply of Natural Gas to D-PNG consumers in
Hyderabad**

Bid Document No. BGL/556/2022-23

**Volume
II of II**

SECTION – 8

**MATERIAL REQUISITION & TECHNICAL
SPECIFICATIONS**



Bhagyanagar Gas Limited

Procurement of Decompression Units (DCU) parts and to assemble for Installation in various societies for Supply of Natural Gas to D-PNG consumers in Hyderabad
Bid Document No. BGL/556/2022-23

**Volume
II of II**

Material Requisition

Project : Procurement of Decompression Units (DCU) parts and to assemble for Installation in various societies for Supply of Natural Gas to D-PNG consumers in Hyderabad

Client : M/s Bhagyanagar Gas Limited

Items : DCU Spare Parts

Tender No. :

Item Nos.	DESCRIPTION	Unit	QTY				
(1)	(2)	(4)	(5)				
1	Design, Supply, Installation and delivery of items upto FOT Site, Hyderabad as per the Material Requisition, attached drawings and Scope of Supply in Bid Document.						
	Working Pressure/Inlet Pressure (in bar)	Outlet Pressure (in bar)	Set Pressure (in bar)	FLOW rate			
1.1	High Pressure Filters	250	-	-	450 SCMH	Nos	6
1.2	High Pressure Slam shut off valve	250	-	28		Nos	6
1.3	High Pressure Regulator	250	60-80			Nos	6
1.4	High Pressure Regulator	60-80	15-20			Nos	6
1.5	High Pressure Regulator	15-20	2-4			Nos	6
1.6	Creep Relief Valve (CRV)1st stage	50-100	-	90	4.5 SCMH	Nos	6
1.7	Creep Relief Valve (CRV)2nd stage	20	-	22	4.5 scmh	Nos	6



1. Scope of Supply:

The successful Bidder (the “Supplier”) shall complete delivery of Goods along-with its incidental services (if any) as per Specification, Scope of Supply/Job within the period stated in Special Conditions of Contract.

Seller’s scope shall include (a) manufacturing of above-mentioned items as per Material Requisition technical specifications; (b) preparation of Quality Assurance / Quality control programme; (c) obtaining Owner’s approval; (d) arranging Inspection and Testing certification; (e) Inspection and obtaining Inspection Release Note; (f) obtaining dispatch clearance; (g) Packing; (h) Transit Insurance, loading on truck/trailer including and unloading of at Bhagyanagar Gas’s store/site.

Owner approval to be obtained after third party Inspection & Testing.

2. Technical Specifications

The technical specifications & drawings for the required items are plotted below. However, BGL will finalize the drawings of the item with the vendor after the placement of order:



Bhagyanagar Gas Limited

Procurement of Decompression Units (DCU) parts and to assemble for Installation in various societies for Supply of Natural Gas to D-PNG consumers in Hyderabad

Volume II of II

Bid Document No. BGL/556/2022-23

DRAFT COPY

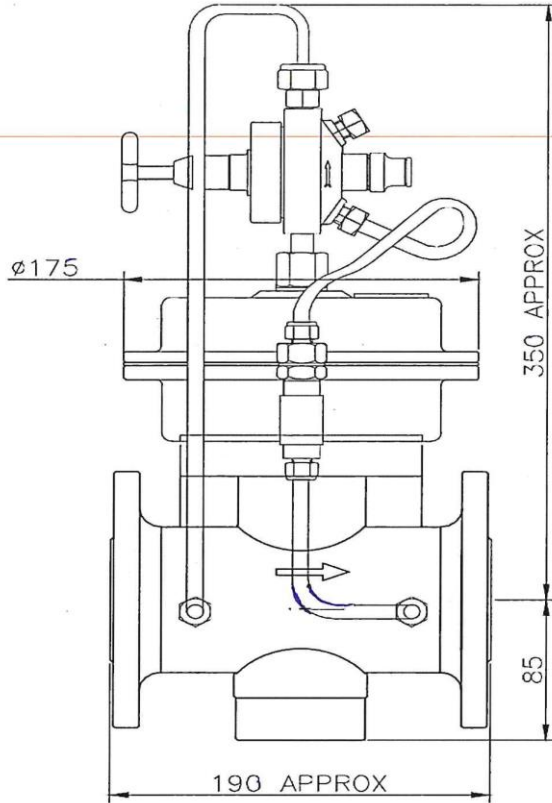

FLANGE DETAILS:-

TYPES OF FLANGE	N.B.	O.D.	P.C.D.	RAISE DIA.	THICK	NO.OF HOLES	HOLE DIA.
ANSI B:16.5 CLASS-150	1 1/2"	127	98	73	18	4	16

REMARKS

TEST: HYDRO TEST ON BODY
PNEUMATIC TEST FOR SEAT LEAKAGE
RT/UT : NA

B	-	-	-	-
A	-	-	-	-
Sr. No.	WAS	MADE	DATE	SIGN

AMENDMENTS

FINISH	Wt.	PART_WT	kg
DRN	ANP	01.12.21	
CHD	ARS	01.12.21	
APPD	AAT	01.12.21	

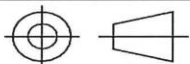

TITLE
PILOT OPERATED PRESSURE REGULATOR
GENERAL ARRANGEMENT
DRAWING & DATA SHEET

UNSPECIFIED CHAMFER-

UNSPECIFIED RADIUS-

REPLACES

REF DRG No.

SCALE

DRG No.

REV

SHEET No SHEET NO

All Dimn.

Bhagyanagar Gas Ltd

GENERAL

IAG NO.	PCV 01
LINE / SIZE	1"NB
P & ID NO.	-
SERVICE	PRESSURE REDUCTION
TYPE	SPRING OPERATED
PRODUCT CODE	-
QUANTITY	1 No.

SERVICE CONDITION

FLUID STATE	CNG			
FLOW RATE- MIN/OP/MAX	1000	1000	1000	SCMH
INLET PRESSURE- MIN/OP/MAX	40	250	250	barg
OUTLET PRESSURE- MIN/OP/MAX	20	50	50	barg
DP SIZING	-	2	2	barg
TEMPERATURE- MIN/OP/MAX	10	85	85	°C
SP. GRAVITY / MOL.WT.	0.7		kg/m³	
VISCOSITY	0.01 CP			
SET PRESSURE	20	barg		
SET PRESSURE RANGE	15 TO 25	barg		

VALVE SIZING DATA

REGULATION	DOWNTSTREAM
CALCULATED Cg MIN./MAX.	85/684
SELECTED Cg	855
PREDICTED NOISE LEVEL dBA-at 1m	<75dBA

VALVE & ACTUATOR CONSTRUCTION

BODY SIZE	25 NB
END CONNECTION	1" BSP (F)
RATING	2500#
HYDRO TEST PR. FOR BODY	375 barg
IMPULSE CONNECTION	INTERNAL SENSING
IMPULSE SIZE	NA
LEAKAGE CLASS	VI

TRIM	SS 304/SS 316
'O' RING	VITON
BONNET	SS304
SPINDLE	SS 316
SPRING PRV	SPRING STEEL
PAD	VITON/PTFE
SEAT	SS 304
BODY	SS 304



Bhagyanagar Gas Limited

Procurement of Decompression Units (DCU) parts and to assemble for Installation in various societies for Supply of Natural Gas to D-PNG consumers in Hyderabad

Volume II of II

Bid Document No. BGL/556/2022-23

DRAFT COPY

Bhagyanagar Gas Ltd	
GENERAL	
TAG NO.	-
LINE / SIZE	3/4\"OD CONNECTOR
SERVICE	CNG
QUANTITY	1 No.

SERVICE CONDITION				
FLUID STATE	CNG			
FLOW RATE- MIN/OP/MAX	450	450	450	SCMH
WORKING PRESSURE- MIN/OP/MAX	40	150	250	barg
OPERATING TEMPERATURE	0 TO 65			°C
DESIGN TEMPERATURE	-10 TO 120			°C
VELOCITY	<40 m/sec.			
Δ P	0.1			barg

BODY	SS 304
'O' RING	NITRILE
DOWL	SS 304
MESH	SS 304
MESH SIZE	5 MICRON
EFFICIENCY	95%

REMARKS

B	-	-	-	-
A	-	-	-	-
Sr. No.	WAS	MADE	DATE	SIGN

AMENDMENTS

FINISH	Wt. PART_WT	kg	TITLE	UNSPECIFIED CHAMFER-
DRN	ANP	22.06.22	FILTER GENERAL ARRANGEMENT DRAWING & DATA SHEET	UNSPECIFIED RADIUS-
CHD	OAK	22.06.22		REPLACES
APPD	AAT	22.06.22		REF DRG No.
				SCALE
			DRG No.	REV
			SHEET No. SHEET_NO	All Dimn. are in mm.



Bhagyanagar Gas Limited

Procurement of Decompression Units (DCU) parts and to assemble for Installation in various societies for Supply of Natural Gas to D-PNG consumers in Hyderabad

Volume II of II

Bid Document No. BGL/556/2022-23

DRAFT COPY

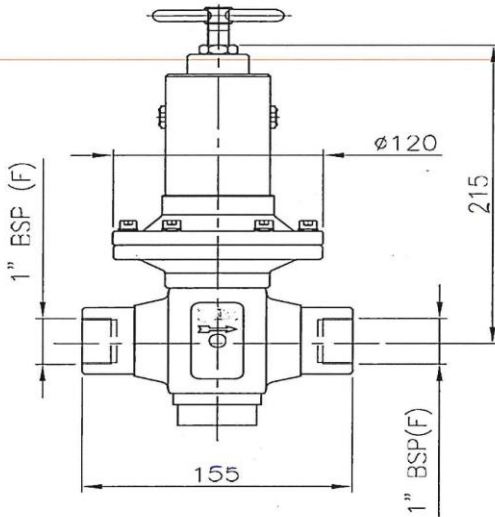

Bhagyanagar Gas Ltd

GENERAL	
LINE SIZE	1" NB
SERVICE	DOWNSTAM REGULATION
TYPE	SPRING OPERATED
PRODUCT CODE	-
QUANTITY	1 No.

SERVICE CONDITION	
FLUID STATE	CNG
FLOW RATE- MIN/OP/MAX	450 450 450 SCM/H
INLET PRESSURE- MIN/OP/MAX	40 250 250 barg
OUTLET PRESSURE- MIN/OP/MAX	60 /C 80 barg
DP SIZING	barg
OPERATING TEMPERATURE	0 TO 65 °C
SP. GRAVITY / MOL.WT.	0.7 kg/m ³
VISCOSITY	0.01 cp
SET PRESSURE	20 barg
SET PRESSURE RANGE	20 TO 30 barg

VALVE SIZING DATA	
REGULATION	DOWNSTAM
CALCULATED C _g MIN./MAX.	85/684
SELECTED C _g	855
PREDICIED NOISE LEVEL dBA-at 1m	<75dBA

VALVE & ACTUATOR CONSTRUCTION	
BODY SIZE	1" NB
END CONNECTION	1" BSP (F)
RATING	2500#
HYDRO TEST PR. FOR BODY	275 barg
IMPULSE CONNECTION	INTERNAL
IMPULSE SIZE	-
LEAKAGE CLASS	VI

TRIM	BRASS
'O' RING	VITON
BONNET	BRASS
SPINDLE	SS 304
SPRING PRV	SPRING STEEL
PAD	PTFE
SEAT	BRASS
BODY	BRASS FORGED

REMARKS
 TEST: HYDRO TEST ON BODY
 PNEUMATIC TEST FOR SEAT LEAKAGE
 RT/UT : NA

B	-	-	-	
A	-	-	-	
Sr. No.	WAS	MADE	DATE	SIGN
AMENDMENTS				

FINISH	WT. PART_WT	kg
DRN	ANP	22.06.22
CHD	OAK	22.06.22
APPD	AAT	22.06.22

TITLE
ADJUSTABLE PRESSURE REGULATOR
GENERAL ARRANGEMENT, DRAWING & DATA SHEET

UNSPECIFIED CHAMFER-
UNSPECIFIED RADIUS-
REPLACES
REF DRG No.
SCALE
DRG No.
SHEET No. SHEET_NO
All Dimn. are in mm.

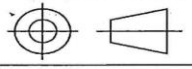



Bhagyanagar Gas Limited

Procurement of Decompression Units (DCU) parts and to assemble for Installation in various societies for Supply of Natural Gas to D-PNG consumers in Hyderabad

Volume II of II

Bid Document No. BGL/556/2022-23

DRAFT COPY

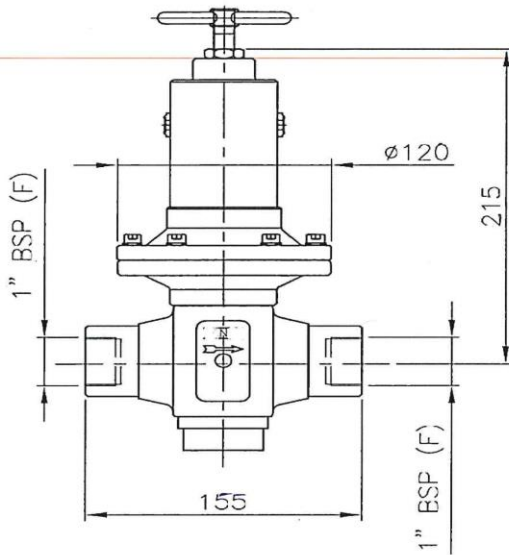

Bhagyanagar Gas Ltd

GENERAL	
SERVICE	DOWNSTREAM REGULATION
TYPE	DIRECT ACTING PISTON TYPE SPRING LOADED
QUANTITY	1 No.

SERVICE CONDITION				
FLUID STATE	CNG			
FLOW RATE- MIN/OP/MAX	450	450	450	SCMH
INLET PRESSURE- MIN/OP/MAX	60	70	80	barg
OUTLET PRESSURE- MIN/OP/MAX	15	18	20	barg
OPERATING TEMPERATURE- MIN/OP/MAX	0 TO 65			°C
DP SIZING				
SP. GRAVITY / MOL.WT.	0.77			kg/m ³
SET PRESSURE				
SET PRESSURE RANGE				

VALVE SIZING DATA	
REGULATION	DOWNSTREAM
CALCULATED CV MIN./MAX.	0.77
SELECTED CV	2.29
PREDICTED NOISE LEVEL dBA-at 1m	<75dBA
VELOCITY	30 M/S

VALVE & ACTUATOR CONSTRUCTION	
BODY SIZE	1" NB
END CONNECTION	1" BSP (F)
HYDRO TEST PR. FOR BODY	412.5 kg/cm ²
PNEUMATIC TEST PR.	302.5 kg/cm ²
IMPULSE CONNECTION	INTERNAL
IMPULSE SIZE	NA
LEAKAGE CLASS	VI

TRIM	BRASS
'O' RING	NITRILE
BODY & BONNET	BRASS FORGED
SPINDLE	SS 316 / SS 304
SPRING PRV	ST. STEEL
PAD	NITRILE
SEAT	BRASS

REMARKS

B	-	-	-	-
A	-	-	-	-
Sr. No.	WAS	MADE	DATE	SIGN

AMENDMENTS

FINISH	Wt. PART_WT	kg
DRN	ANP	22.06.22
CHD	OAK	
APPD	AAT	

TITLE
ADJUSTABLE PRESSURE REGULATOR
GENERAL ARRANGEMENT
DRAWING & DATA SHEET

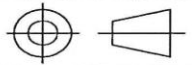

UNSPECIFIED CHAMFER-	
UNSPECIFIED RADIUS-	
REPLACES	
REF DRG No.	
SCALE	
DRG No.	REV
SHEET No. SHEET_NO	All Dimn. are in mm.



Bhagyanagar Gas Limited

**Procurement of Decompression Units (DCU) parts and
to assemble for Installation in various societies for
Supply of Natural Gas to D-PNG consumers in
Hyderabad**

**Volume
II of II**

Bid Document No. BGL/556/2022-23

DRAFT COPY

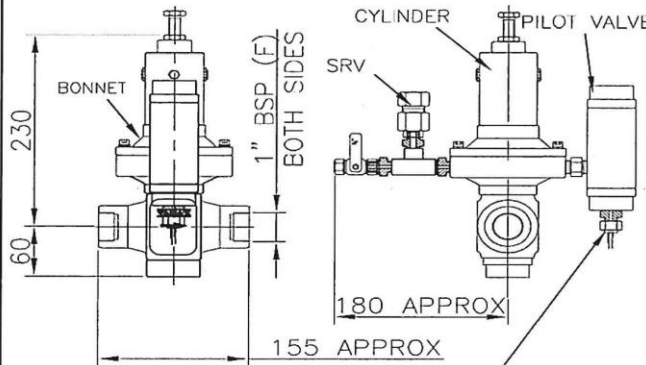

SENSING TO BE
CONNECTED TO DOWN STREAM
OF THE PR.REGULATOR
SIZE:- 1/4" BSP(F) SS 316

Bhagyanagar Gas Ltd

GENERAL	
QUANTITY	1 No.

SERVICE CONDITION				
FLUID STATE	CNG			
FLOW RATE- MIN/OP/MAX	450	450	450	SCMH
INLET PRESSURE- MIN/OP/MAX	40	250	250	barg
SET PRESSURE	28			barg
OPERATING TEMPERATURE	0 TO 65			°C
SP. GRAVITY	0.77			kg/cm ³
SET PRESSURE RANGE	22 TO 34			barg

VALVE SIZING DATA	
REGULATION	OVER PRESSURE SHUT OFF VALVE
CALCULATED CV	.077
SELECTED CV	2.29
PREDICTED NOISE LEVEL dBA-at 1m	<75dBA

VALVE & ACTUATOR CONSTRUCTION	
END CONNECTION	1" BSP (F)
HYDRO TEST PR. FOR BODY	412.5 kg/cm ²
IMPULSE CONNECTION	EXTERNAL
IMPULSE SIZE	1/4" (SS 304)
LEAKAGE CLASS	VI

TRIM	BRASS
'O' RING	NITRILE
BONNET	BRASS FORGED
SPINDLE	SS 316/SS 304
SPRING	ST STEEL
PAD	NITRILE
SEAT	BRASS
BODY	BRASS FORGED

REMARKS

TEST: HYDRC TEST ON BODY
PNEUMATIC TEST FOR SEAT LEAKAGE

RT/UT : NA

B	-	-	-	
A	-	-	-	
Sr. No.	WAS	MADE	DATE	SIGN
AMENDMENTS				

FINISH	WT.	PART_WT	kg	TITLE	UNSPECIFIED CHAMFER-	
DRN	ANP	22.06.22				UNSPECIFIED RADIUS-
CHD	OAK	22.06.22				REPLACES
APPD	AAT	22.06.22				REF DRG No.
				<p align="center">SLAM SHUT OFF VALVE GENERAL ARRANGEMENT DRAWING & DATA SHEET</p>	SCALE	
					DRG No.	REV
SHEET No. SHEET_NO					All Dimn. are in mm.	



Bhagyanagar Gas Limited

**Procurement of Decompression Units (DCU) parts and
to assemble for Installation in various societies for
Supply of Natural Gas to D-PNG consumers in
Hyderabad
Bid Document No. BGL/556/2022-23**

**Volume
II of II**

SECTION – 9

SCHEDULE OF RATES (SOR)



Bhayanagar Gas Limited

**Procurement of Decompression Units (DCU) parts and
to assemble for Installation in various societies for
Supply of Natural Gas to D-PNG consumers in
Hyderabad
Bid Document No. BGL/556/2022-23**

**Volume
II of II**

**REFER E-TENDER NO.: BGL/556/2022-23 IN
E-TENDERING WEBSITE /PORTAL -
(<https://petroleum.euniwizarde.com/>)
FOR SCHEDULE OF RATES**



**Procurement of Decompression Units (DCU) parts and
to assemble for Installation in various societies for
Supply of Natural Gas to D-PNG consumers in
Hyderabad
Bid Document No. BGL/556/2022-23**

Volume
II of II

Requisition, attached	Drawings and Scope of Supply in Bid Document.																	
1.1	High Pressure Filters	250	-	-	450 SCMH	Nos	6											
1.2	High Pressure Slam shut off valve	250	-	28		Nos	6											
1.3	High Pressure Regulator	250	60-80			Nos	6											
1.4	High Pressure Regulator	60-80	15-20			Nos	6											
1.5	High Pressure Regulator	15-20	2-4,			Nos	6											
1.6	Creep Relief Valve (CRV)1st stage	50-100	-	90	4.5 SCMH	Nos	6											
1.7	Creep Relief Valve (CRV)2nd stage	20	-	22	4.5 SCMH	Nos	6											
Total amount inclusive of all applicable taxes & duties in Rs.(A)																		